



The Doorknob Collector

Number 43

September–October 1990

Convention highlights — See page 2

The building



Above, an outside view of "The building."

Left, Conventioneers are enthralled by Ed Thrall at "The building."



Above, the dance floor at "The building." Right, Charles Wardell and Win Applegate examine the lower level.



Convention a huge success

— by Len Blumin

P. & F. Corbin was a leading hardware company of the later 19th century, with factories in New Britain, Connecticut. It was thus fitting to have Corbin as the theme of the Convention of ADCA, as we gathered at the Ramada Inn in East Windsor, Connecticut from August 2nd to the 5th.



Ed and Flicka Thrall were our most gracious hosts, and aided by Norman and Cheryl Blam and Win Appelgate, provided a program of great interest and excitement. Day one was devoted to historical research, as we ventured to Hartford for a tour of the Capitol Building, which has been recently restored. The Building featured beautiful hardware by Corbin, along with fine architectural detailing. Just across the street was the State Library, which contains important research material, including old hardware catalogs. In the afternoon Tom Hennessy led a smaller group to the New Britain Library, where curator Arlene Palmer kindly showed us their extensive P.&F. Corbin catalog collection. We couldn't help but feel that we had found some of our "roots."



Day two provided the usual excitement of setting up displays and trading, heightened by the presence of a number of new members, whose enthusiasm and friendliness were contagious. A fine buffet dinner was



followed by our official annual general meeting, at which the board of directors was re-elected and the formation of a museum committee was announced. Members of ADCA wishing to serve on the board or to be a member of the museum committee should contact me.

See Convention, pg. 8

THE OPEN DOOR

by ray nemec

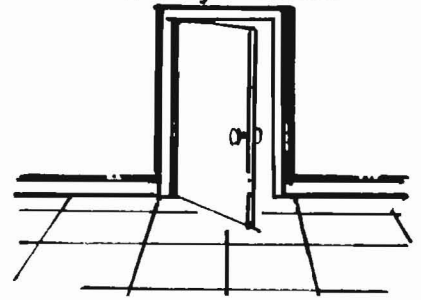

The 1990 convention was attended by members from 19 states and one providence. There were 52 memberships represented by about 80 people. Eighteen members were on hand for their first convention.

Most of the pictures presented in this issue were by Bridgitte Ostiguy of Quebec city. The balance by Len Blumin and me. We owe a very special thanks to Brigitte for her contribution.

Rich Kennedy was on hand for his first convention. It was 13 years ago, in March 1977, that Rich published a newsletter for doorknob collectors, the forerunner of our current newsletter. His pioneering was a major contribution in uniting collectors.

We were sorry to learn of the death of George Doyle's wife, Lois, who died after a long illness early this year.

Fred and Ethladel Magnus also suffered a loss when their son, Robert, died on May 19th in San Francisco. ■

The Doorknob Collector

Published six times a year by Antique Doorknob Collectors of America, Inc. P.O. Box 126, Eola, IL 60519-0126. Raymond and Loretta Nemec, Editors. Phone: 1-708-357-2381

Printed by Sun Printing, Naperville, IL Annual Membership in USA: \$20.00. Foreign rates on request.

Chicago hardware was unique

by Maudie Eastwood

Doorknob collectors are seeking information on Chicago hardware and its Illinois manufacturer. Several Chicago based hardware companies produced door hardware but the collectors are referring to the Chicago Hardware Manufacturing Company otherwise known as plain "Chicago" or "Chicago Hardware." Their locks are marked: Chicago, Niles-Chicago, or C.H.MFG.Co.

For two reasons, early-birds among Chicago devotees have recently turned on to all Chicago collections or Chicago sections within their general collections.

First, to escape the frustration of trying to arrange one of those long-shanked specimen in an average display. Second, this unique brand deserves its own niche and will not get out of hand for transporting and showing.

An introduction to Chicago Hardware will be found on pages 157 and 158 of *Antique Builders' Hardware (ABH)*. Pages 159-161 cover Niles locks and 162-164, 40 knob and plate designs.

Chicago catalogs are seldom found. Catalog NO.6, dated December 1, 1895, is massive. Besides the Chicago line, it provided a thumb-nail sketch of policy and operation. Page iii addresses those "interested in substantial progress in the development of Artistic Builders' Hardware" and announces a full line of House Hardware. Their improved lock (Niles Patent) is

extolled and Special Design Hardware orders solicited.

Knobs in Chicago's 1895 catalog were "invariably fitted with long escutchions plates." Separate roses were not an option but were cast in-one with the plate. The thimble - the elevation through which the knob shank passes or bears upon - was unusually tall and wide, a Chicago feature. Earlier escutchions, as with other companies, were quite irregular.

In addition to the metal knobs in Chicago's 1895 catalog (has anyone seen NO's 1 thru 5?), other types were shown or offered special order. Jet, mineral and porcelain were stock items. Wooden knobs were stock in eight woods and three usual shapes. Egg, oval, and round fluted shapes and four exotic woods were special order items.

Loose spindles and door thickness were not Chicago worries. The knobs were shank-less, although several Chicago design's have been found on knobs with a conventional shank and requiring a spindle. Laurel and LeGrande patterns, page 163 ABH, have been thus found. Sager, of West Chicago had these same patterns in their 1937 catalog. By the date Sager was an operating division of Yale & Towne. Further research would possibly show an alliance between these three companies.

Chicago hardware was mounted on many important buildings and homes across America. This company became a manufacturer of importance

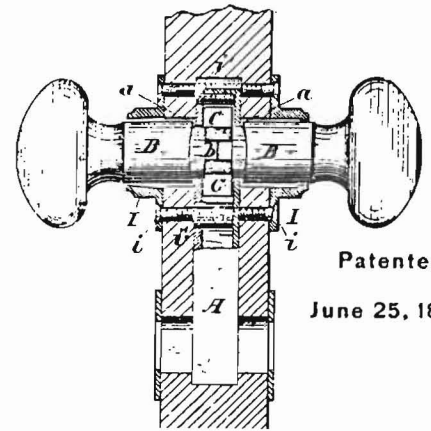

M. C. & S. S. NILES.
Reversible-Latch.

in architect Louis Sullivan's day, the 1880's and 1890's. With Yale & Towne and Corbin, Chicago was a force in providing proprietary and emblematic hardware from architect inspired designs. The old Federal Building and the Shiller (demolished in 1961) were both Chicago furnished. A simple "US" graced the Federal Building and a Sullivan-type design, the Shiller Building.

Dates found on patent copies, Carpentry and Building ads, and Chicago Hardware installations place the span of Chicago's greatest activity in the last two decades of the 19th century. Virtually no recognition was given them in manufacturers lists, hardware magazines, or company comparison charts after the turn of the century. Seemingly, they rose to prominence on the Niles lock, gambled their future on it and the future brought unit and bore-in lock assemblies perfected by competitors and preferred by builders. That, or they were bought out and their line shelved. ■

FOURFOLD SYMMETRY

- H-285 Unusual vernacular, Bronze face, iron back with same design.
H-286 Crude cast iron, circa 1880.
H-478 Wrought steel, circa 1905.
H-479 Sharp casting of rococo acanthus leaves.
H-480 Cast iron.
H-481 "LeRoy." Russell & Erwin, 1909 catalog. Wrought steel.

H-285



H-479



H-286



H-480

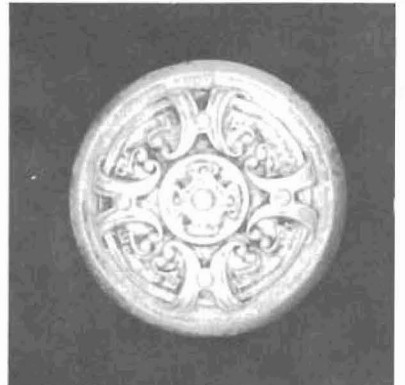

H-478

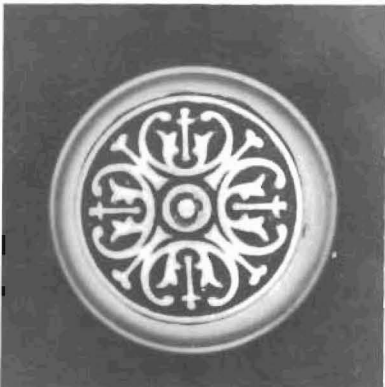

H-481



Connecticut was fun



AUTHORS

Tom Hennessy, Maudie Eastwood and Len Blumin pose with copies of books they have written on doorknobs and related hardware . (Photo by Ostiguy)



EDITORS

Rich Kennedy, first editor of THE DOORKNOB COLLECTOR is greeted by current editors, Lorreta and Ray Nemecc (Photo by Ostiguy)

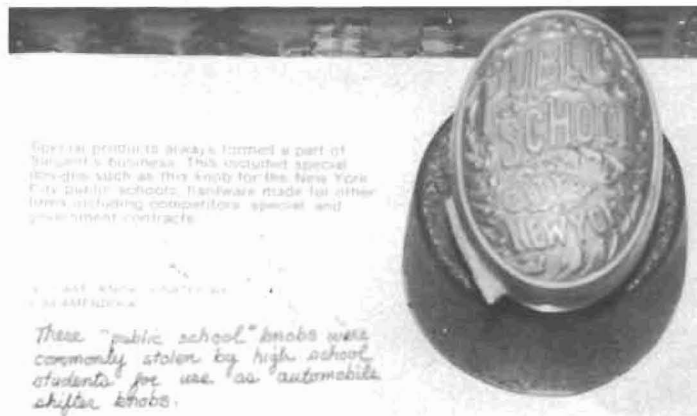

Copy the products always formed a part of Sargent's business. This included special one-day sales at this knob for the New York City public schools. Hardware made for other lines including competitors special and government contracts.

These "public school" knobs were commonly stolen by high school students for use as automobile starter knobs.



Upper pictures , at the Lock Museum. Lower left, State Capitol building at Hartford. Lower right (standing L to R), Nancy Sandwick, Judy Niedenthal, Lois Jackson, Tom Hennessy, Jr., Helen Byington, Maudie Eastwood, Emmet Wiemer, (kneeling) Loretta Nemecc.



36. Don & Dixie
Friedriam

37. Julie
Mann

38. Jeannie
Orr

39. Mr. Orr

40. Tom
Hennessy,
Jr.

41. Tom
Hennessy

42. Joe Mann

41. Richard &
Carolyn Hubbard

43. George Doyle

44. Dale
Sponaugle

45. Rita
Hennessy

46. Steve
Menchhofer

47. Don
Warming

48. Barbara
Menchhofer

49. Donald
Pearson

50. Becky
Pearson

51. Martha Mueller 52. Joe Mueller

53. Mike
Maldanado

54. John
Osborne

55. Helen
Byington

56. Bill
Byington

57. Joe Brusnicki

58. Marie
Osborne

59. Tecla & Homer
Snow

62. Loretta & Ray
Nemec

60. Lois
Jackson

61. Judy
Niedenthal

63. Dolores
Fellenz

64. Emmet
Wiemer

65. Marjorie
Wiemer

66. Claude & Pat
Knox

67. Debbie
Fellenz

68. Rick Kelly

69. Arnie Fredrick

70. Rosaria
Sinisi

71. Ethladel & Fred
Magnus



1. Lill &
Richard
Balasa

2. Carol & Win
Applegate

3. Betty
Madison

4. Florence
Jarvis

5. Cheryl
Blam

6. Charlie
Wardell

7. Hilary
Applegate

8. Marge
Bornino

9. Lawrence
Bolen

10. Norman
Blam

12. Jennifer
Bornino

11. Don Dion

13. Joe
Bornino

14. Frances
Bolen

15. Peggy Lee Hobbs

16. Brigitte Ostiguy

17. Nancy Sandwick

18. Carlos
Ruiz

19. Patti & Len
Blumin

20. Dean
Campbell

21. Edith
Campbell

22. Rich
Kennedy

23. Paul
Carton

24. Bill Causey

25. Bob Beaulieu

26. Ed
Thrall

27. Mary
Coen

28. Richard Coen

29. Miriam
DeLange

30. Bill Bray

31. Flicka
Thrall

32. Maude
Eastwood

33. Mark
Davidovich

34. Gene
DeLange

35. Robert
Rodder



CONVENTION

Continued from page 2

The third day we voted on the displays. Arnie Fredrick captured top award for the Best Corbin Display, with panels featuring tastefully arranged Corbin hardware of all types, from knobs to bells. Claude and Pat Knox placed second, with an impressive knob display covering the entire spectrum of Corbin design. Joe and Julie Mann won for the best non-metallic, with a pleasing basket of knobs presented as a floral arrangement, and Florence Jarvis took honors for the best non-Corbin display, with carefully chosen pieces that included a spectacular dragon knob. Our meeting was well-attended by the public, who were kept informed through excellent newspaper and T.V. coverage.

The auction was a fitting climax to events at the Ramada. Primed by a gourmet dinner, we met for the auction, "Colonel" Bill Causey was in his best form; as with wit and charm he conducted a spirited auction, the highlight of which was a fine Russell and Erwin "Lion" (A-102). A sophisticated computer program, designed by Win



Appelgate and written by Dov Yaron and generously donated to the club, allowed for rapid and accurate tabulation of the auction accounts, which in turn provided Arnie with a decent night's sleep.

The best was yet to come. On the last day we drove to nearby Broad Brook. On the Thrall's farm sits a structure called "**The Building**", built by Ed over a period of years with salvaged goods, using skill and imagination few could match. **The Building** sits sadly idle, shackled by town bureaucrats and threatened by a tax sale. Should it survive it will become a local historic landmark, and a testament to one couple's strength and tenacity. Ed, hypnotized the group with a stirring account of **The Building's** trials and tribulations, while Flicka prepared a wonderful buffet luncheon,

featuring fresh corn on the cob.

In the afternoon we boarded a bus for Terryville, where we were privileged to be guided through the Lock Museum of America by curator Tom Hennessy and assistant curator Tom Hennessy, Jr. The museum contains a wonderment of material, with locks and hardware of every type. Some of the hardware shown represents the finest ever produced, and all pieces are carefully and beautifully displayed. We were breathless with awe at the end of the too-brief visit, and want to express our deepest thanks to the Hennessy's for their hospitality.

ADCA thank Ed and Flicka Thrall for presenting us with one of the best ever conventions. Next year we will journey to fabulous Lake Tahoe, California, where hosts Marge and Joe Bornino will greet us for the tenth anniversary of the founding of ADCA. Watch upcoming newsletters for details. ■



FOURFOLD SYMMETRY
(continued)

- H-482 Similar to Corbin's "BALMORAL"/"CHALONS," 1905 catalog.
H-489 "DIJON," Gothic, Russell & Erwin, 1909 catalog.
H-490 Simple effective design.
H-491 Wrought brass, circa 1905. Possibly grapes.
H-492 Gothic, with rope border.
H-493 Wrought, Art Deco type. Nice and simple.

H-482

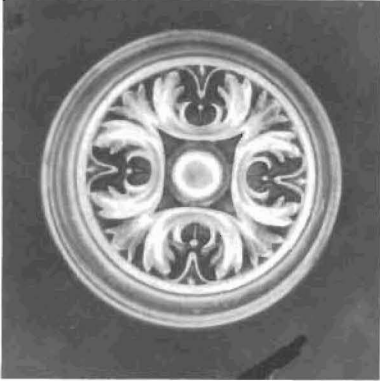

H-491



H-489

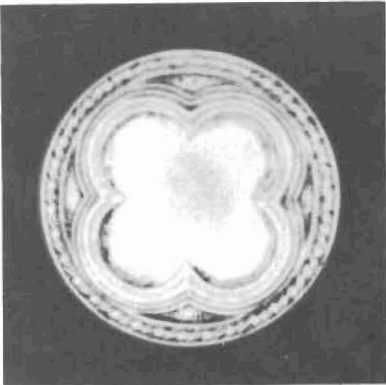

H-492



H-490



H-493



Stolen doorknobs found

by Carl Anderson

Maudie Eastwood had 291 doorknobs returned to her last week, after Hans Tannler found them across the road from the 18th fairway at Alderbrook Golf Course.

Burglars last August took most of Eastwood's antique hardware and doorknob collection, and until now she has had no word on the stolen goods.

Tannler said he found the doorknobs while he was on his regular exercise route to the golf course last Thursday about 8:30 a.m.. He said he saw a blanket about five or six feet off the roadway in the field, kind of lumpy, with the letters "PLC" on it, became curious, kicked at it, lifted one corner and "saw a great many doorknobs."

Then he took his pickup back to the scene and put the doorknobs in the truck one by one because the blanket

was so heavy with them all, he said. Then he called Eastwood, suspecting they were hers, and Eastwood immediately recognized them when he brought them to her.

She said he asked how she knew so quickly they were hers, and she told him, "Those are my children."

Eastwood noted that the found doorknobs represent "a significant portion of those stolen." Many of the iron ones are rusted and the wooden ones have soaked up enough water to have dark streaks, she added.

She explained that she has taken flyers up and down the coast and every antique dealer in the state knows about the stolen collection, so the burglars would have had a difficult time getting rid of them for a profit.

Eastwood said she still is offering a reward for return of hardware stolen from her collection.



TREASURE RETURNED – Hans Tannler found 291 of the doorknobs stolen from Maudie Eastwood last August, as he was exercising near Alderwood Golf

Course. Above, Eastwood displays the collection, somewhat worse for the wear due to weather exposure.

(H-H photo by Carl Anderson)

(Reprinted from the June 6, 1990, issue of the Tillamook, Ore., Headlight-Herald.)

Letters



Dear Ray & Loretta

Please accept the enclosed check as my application for membership in the "Antique Doorknob Collectors of America."

As predicted by many at the convention, I was bitten. I found the membership to be one of the most friendly groups it has been my experience to come in contact with.

The purpose of the organization, I think, will provide many hours of enjoyment to me and anyone who shows an interest.

I look forward to the newsletters and any other correspondence regarding ADCA.

Thank you.

Yours very truly,
Bettie J. Madison

Dear Nemecks:

Before things get too hectic again we wanted to take a few minutes to express our pleasure at being able to attend the recent ADCA convention and our appreciation to all those who worked so hard to make it a memorable event. As first time attendees we were apprehensive - no one will know us, our duplicates for trading will have no interest since everyone has more than we do, etc.

It didn't take fifteen minutes to dispell all those concerns. The veterans couldn't have been more welcoming, interested and helpful. After trading over 20 knobs (all one for one) on Friday that concern was overcome as well.

We gained a lot of new ideas regarding display, transporting knobs, and storage. We learned a lot from a wide variety of people and established what we are sure will be some interest relationships in the coming years. The meals were great and the company most enjoyable.

We are sorry that time did not permit our remaining for the Sunday activities - perhaps next time.

All in all we saw that what come thru in the newsletter - that this is a close knit, warm group of people with a common interest (or perhaps obsession) is a very time reflection of reality.

We especially appreciate you including us at the dinner table Friday and making us feel most welcome and also all your work on producing the newsletter. This was our first ADCA convention - it won't be the last.

Sincerely,
Becky & Don Pearson



1990 - 1991
ANTIQUÉ DOORKNOB COLLECTORS OF AMERICA
Board of Directors

President	Len Blumin #3	Mill Valley, CA
Vice President	Win Applegate #110	Hamilton Square, NJ
Secretary/Treasurer	Ray Nemeck #8	Naperville, IL
Board Member	Bill Byington #41	Iowa City, IA
Board Member	Dean Campbell #11	Newberg, OR
Board Member	Mark Davidovich #25	Carpinteria, Ca
Board Member	Maude Eastwood #2	Woodinville, WA
Board Member	Arnie Fredrick #1	Waverly, IA
Board Secretary	Julie Mann #70	Speedway, IN



**FROM THE ARCHIVES
WITH ARCHIVISTS**

Steve & Barb Menchhofer

The convention is over but the memories linger on! What a terrific time we had in Connecticut "door-knobbing" with everyone. Renewing old friendship, making new ones, educating ourselves about doorknobs, buying, selling, and trading -- one should never miss an ADCA convention if at all possible. It's great!

Eight new catalog copies were added to the Archives and we offered them for the first time at the convention. We will be sending out updated order forms with these new additions in the next issue of **THE DOORKNOB COLLECTOR** to all the members.

We hope you had a chance to stop by the Archives table at the convention and look over some of the catalog copies that were there. Some orders were placed then but we will hold these until the order forms go out in the next issue and then process all orders at one time to save wear and tear on the master copies.

Charles and Alva Bednar have sent a copy of selected pages from P & F Corbin-Bronze Hardware

List, 1874-5 for the Archives. At the convention, Loretta & Ray Nemec donated copies of two catalogs for the Archives. They are Yale & Towne Manufacturing Company - Catalog #16 and Haw Hardware Company-Jobbers of Hardware, 1916. Our thanks to the Bednars and the Nemecs for their kindness.

If you have a catalog that you would rather copy yourself and then loan or donate the copy to us that's fine. Let us know. Or if you have any questions about the Archives or donations to either the Archives or the Emil Miller Memorial Library, please write or call us. ■



ROSTER UPDATE

Address change:

Maude Eastwood #2
P.O. Box 2609
Woodinville, WA 98072-2609
Phone: 206-483-5848.



Members are reminded that your dues entitle you to advertise items for sale, trade or wanted at no charge.

FOR SALE. Have knobs, plates, mortise locks, door pulls, hinges. Send your "want list." Ruth Wilder #125, 13244 Girdled Rd., Painesville, OH 44077. Phone: 216-254-4075.

FOR SALE. Huge selection of cast and stamped knobs and complete lock sets. Brass, steel, chrome and wood available. Send us your requests. Refer to Victorian Decorative Art numbers, or send drawing or photocopy. Caerhl Irey, Architectural Antiques #213, 801 Washington Ave., N., Minneapolis, MN 55401. Phone 612-332-8344.

FOR SALE. Very extensive sets of Norwalk "Marquis" (N-101 VDA) interior and exterior knobs, mortises, drawer pulls, plates, etc. (Probably enough for an entire hours.) Selling as sets only. Beautiful condition, serious buyers inquire. Caerhl Irey, Architectural Antiques #213, 801 Washington Av., N., Minneapolis, MN 55401. Phone 612-332-8344.

WANTED. Will the person who at the convention kindly gave me an article on the "Old Executive Office Building", please contact me. Maude Eastwood, Phone: 206-483-5848.

